

Above: U8406, 375kg. Right: U8401, 15000kg.

Unisystem's U235 series crane scales are designed for accurate weighing. They have multiple range, which means that each model covers a wide range. The display may be tilted, in order to improve the visibility from below. The material is stainless steel and metallized polycarbonate. The scale may be used temporary outdoors in rain.

A fast response, analog filter attenuates mechanical oscillations, and the result is a stable display. On request the time may be increased in order to eliminate very slow oscillation, e.g., on ships.

The attenuation of electrical interference is excellent, and mobile telephones do not interfere.

In spite of the big rechargeable battery, the weight is low. There is discharge protection. Battery charger is included.

Accurate load cells and well-designed suspension of hook and master link means very good repeatability.

Without damage, the overload may be 1.5 times. Hook and master link are ordered separately for not certified models. Swivel with ball bearing is recommended in order to protect the scale when a big load is rotated.

The indicator has a combined zero and tare pushbutton. When pushed quickly, the indicator switches between net and gross. A long push displays the deviation from calibration zero. This is a way to test the load cell.

- ★ Very wide measuring range and high accuracy.
- ★ Excellent suppression of mechanical oscillations.
- ★ The display may be tilted for better readability.
- ★ Big battery and long operation time.
- ★ Good humidity protection.
- ★ Favorable price.
- ★ U840 series have very low height.
- ★ Certified verifiable models. OIML class III

SPECIFICATION.

Measuring range: Multiple range. The resolution is changed in 2 or 3 steps, e.g., 1, 2 and 5 at increasing weight. See the table.

Accuracy: 5 to 35°C. Scales including 3 tons have ±0,03% of the displayed weight, above 3 ton ±0,06%.

Certified scales are accurate according to OIML class III
Temperature range: -10 to +40°C.

Display: 25mm, from 15000kg, 57mm high intensity LED.

Dimensions:: Bredd 244mm. Djup 249mm.

U8400: Width 284mm. Deapth 308mm.

≥15000kg: Width 406mm. Deapth 448mm.

The height is with hook and link for certified scales.

Battery: 12V, 7Ah (14Ah from 15000kg) sealed led battery. Discharge protection. Operating time minimum 30 hours, dependent on how many LED segments are on. Maximum charging time is 12 hours.

Normally the scale is switched off after 4 minutes, when not operated, Optional 1, 17 minutes or infinite time.

Environments: Operating temperature -10 to +45°C.

Dust and water protection according to IP65.

Without any damage, the load may be 1.5 times the max capacity. Ultimate overload is minimum 4 times.

Models	Multiple range capacity. Range/interval in kg.			Height mm	Weight kg
U23510	300/0.1	120/0.05	60/0.02	156	6.9
U23520	1000/0.5	600/0.2	300/0.1	168	7.1
U23530	3000/1	1500/0.5	600/0.2	230	8.9
U23540	5400/2	3000/1	1500/0.5	309	12.4
U23550	10000/5	4000/2	2000/1	407	17.8

III Certified and verified crane scales.
Hook and link are included. Ball bearing swivel to 8000kg.
37500kg has no swivel.

U84060	375/0.2	300/0.1	150/0.05	406	8.0
U84070	750/0.5	600/0.2	300/0.1	406	8.0
U80020	1000/0.5	600/0.2		433	8.2
U80030	2000/1	1500/0.5		492	10.1
U84080	3200/2	3000/1	1500/0.5	559	11.2
U80040	5000/2	3000/1		675	15.8
U84000	7500/5	6000/2	3000/1	498	22.3
U84010	15000/5	6000/2		566	50.5
U84040	22500/10	15000/5		768	66.7
U84020	30000/10	15000/5		832	109
U84050	37500/20	30000/10	15000/5	859	129

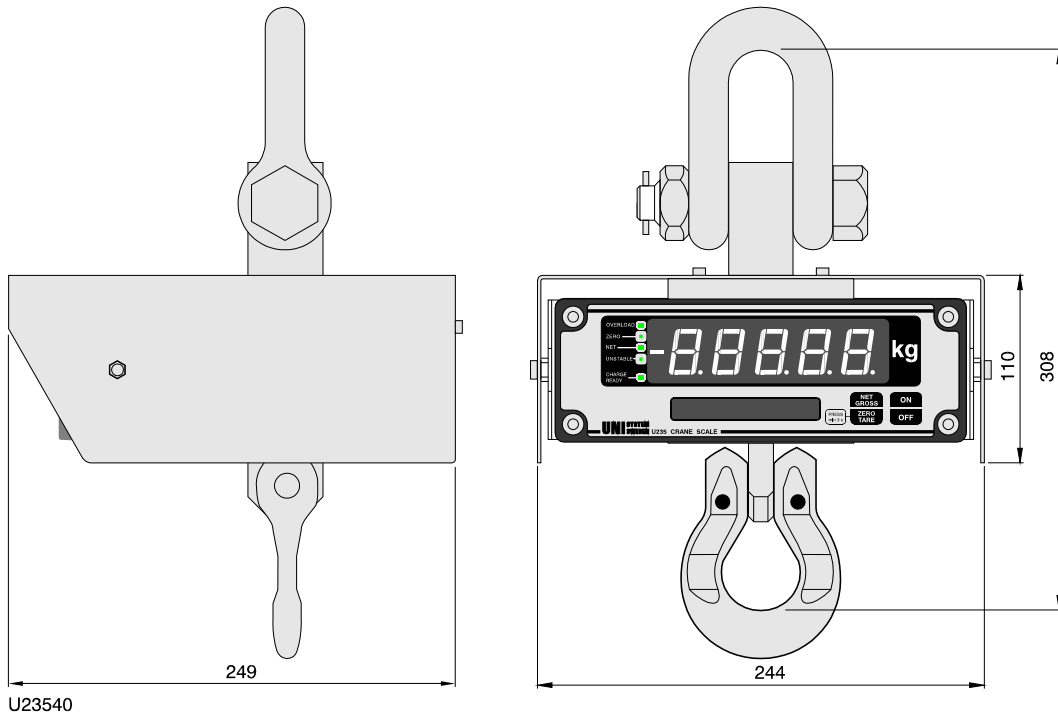

Accessories.

U2360 Radio remote control.

Hooks and master link. Dimensions in mm. Capacity and total weight in kg.

Model	Cap.	Description.	A	B	C	D	E	F	G	H	Weight
U1343	1250	Hook with latch 2000kg, master link.	60	100	10	11	25	27	22	98	0.64
U1344	1250	Safety hook 2000kg, master link.	"	"	"	10	25	34	20	129	0.85
U1345	1250	Swivel safety hook, ball bearing 2000kg, master link.	"	"	"	12	27	36	23	183	1.3
U1346	3200	Hook with latch, master link.	80	140	17	14	32	34	28	122	1.5
U1347	3200	Safety hook, master link.	"	"	"	13	32	42	25	162	1.9
U1348	3200	Swivel safety hook, ball bearing, master link.	"	"	"	15	37	44	29	218	2.6
U1349	5400	Safety hook, master link.	90	150	19	15	40	50	30	195	3.0
U1359	5400	Swivel safety hook, ball bearing, master link.	"	"	"	19	43	54	38	276	4.8
U1336	6300	Safety hook 8000kg, master link.	"	"	"	18	50	60	38	237	5.1
U1337	6300	Swivel safety hook 8000kg, ball bearing, master link.	"	"	"	22	50	63	49	334	8.1
(U8400)	8000	Swivel hook with latch, ball bearing, master link.	95	160	22	22	50	49	43	277	6.6
E1538	8000	Hook with latch.	-	-	-	22	50	49	44	184	3.2
U1338	11500	Hook with latch 12500kg, half link and master link.	110	190	25	-	48	59	50	252	8.4
U1339	11500	U1338 with ball bearing swivel.	"	"	"	-	"	"	"	399	14.6
(U8401)	15000	Swivel hook with latch 16000kg, master link.	105	180	28	32	68	48	66	306	13.4
E1545	15500	Hook with latch.	-	-	-	30	50	72	59	240	8.0
(U8404)	22000	Swivel hook with latch, master link 25000kg.	150	250	38	38	106	70	76	421	29.6
E1549	21600	Hook with latch.	-	-	-	32	66	80	75	280	12.8
(U8402)	30000	Swivel hook with latch, master link.	150	250	40	38	106	82	93	459	40.0
E1550	32000	Hook with latch.	-	-	-	38	76	90	80	318	17.0
(U8405)	37500	Hook with latch, master link.	180	300	45	51	114	76	116	462	59.6

